

THIS DRAWING IS UNPUBLISHED. RELEASED FOR PUBLICATION 2006  
 © COPYRIGHT 2006 BY TYCO ELECTRONICS CORPORATION, ALL RIGHTS RESERVED.

LOC	DIST	REVISIONS			
P	LTR	DESCRIPTION	DATE	DWN	APVD
1	-	B	ECR-10-021916	25OCT2010	UA GT

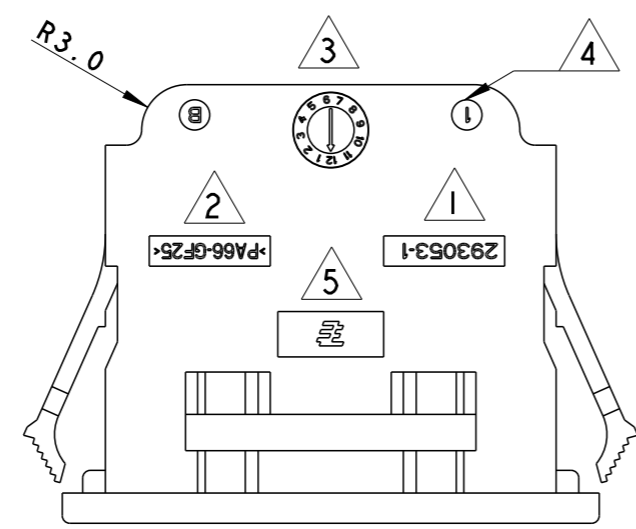
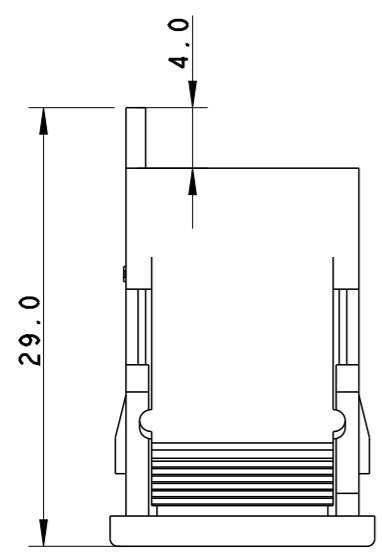
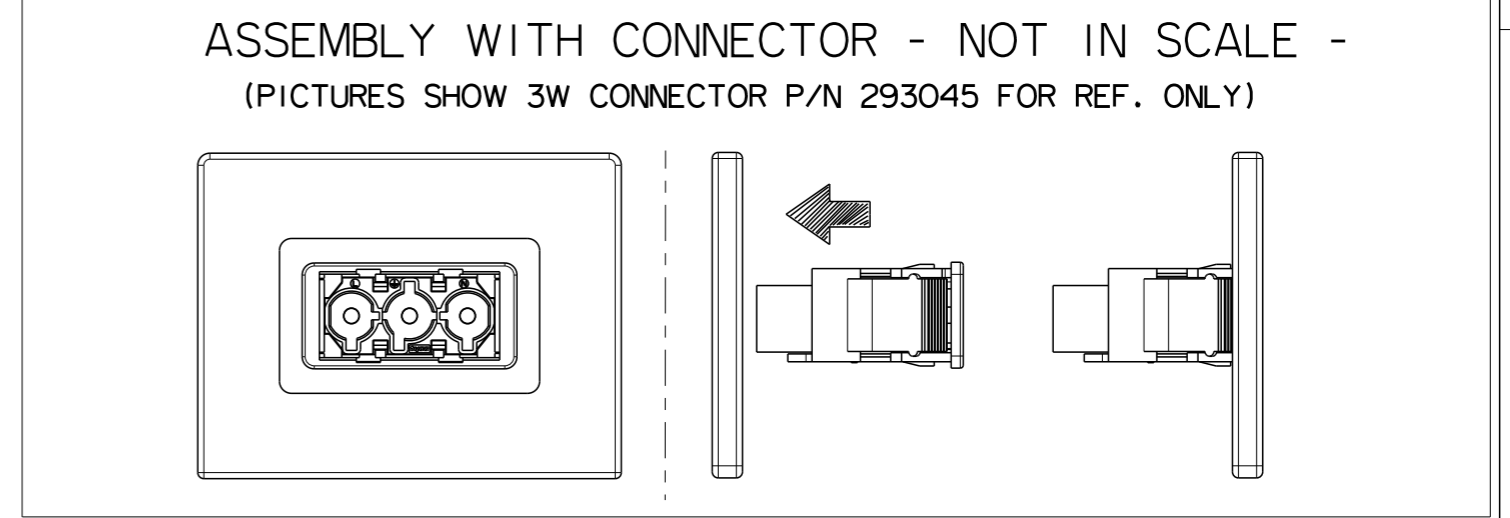
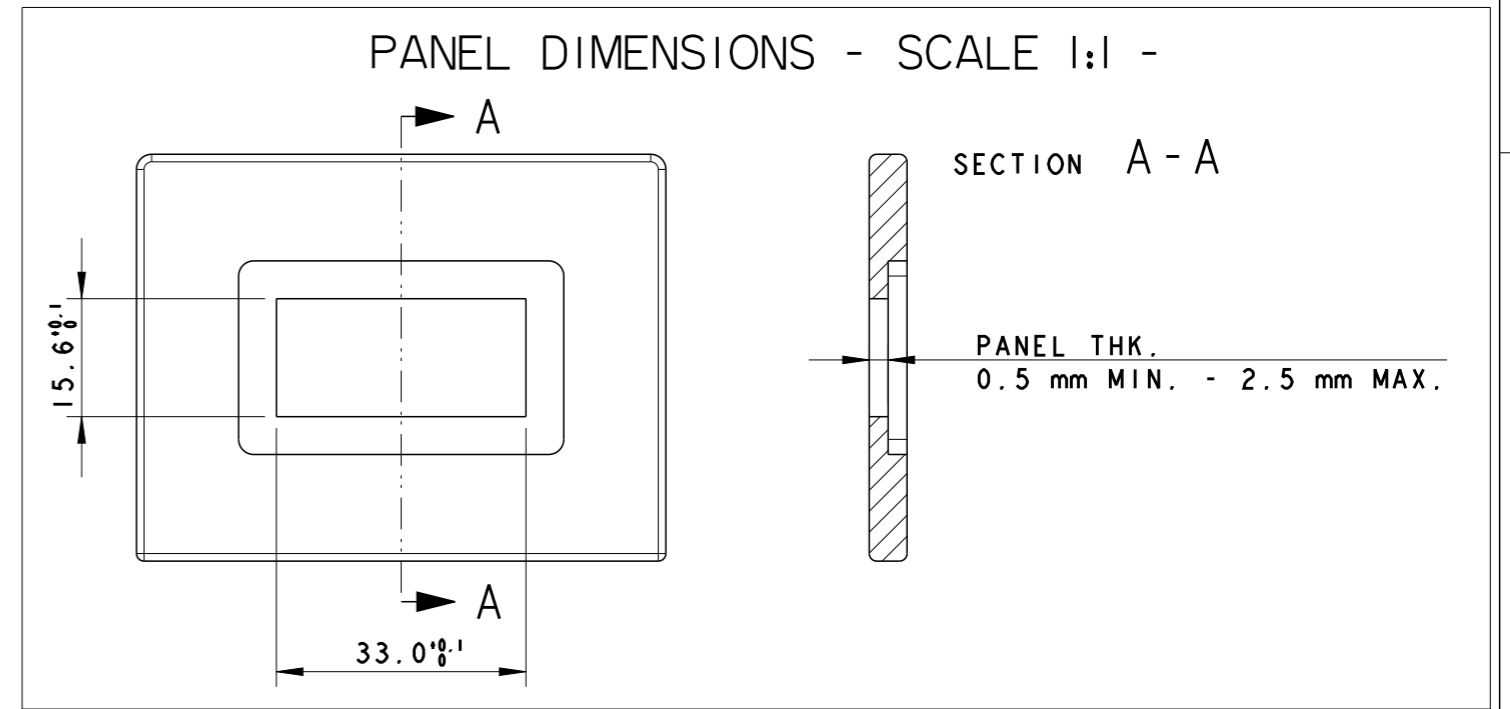
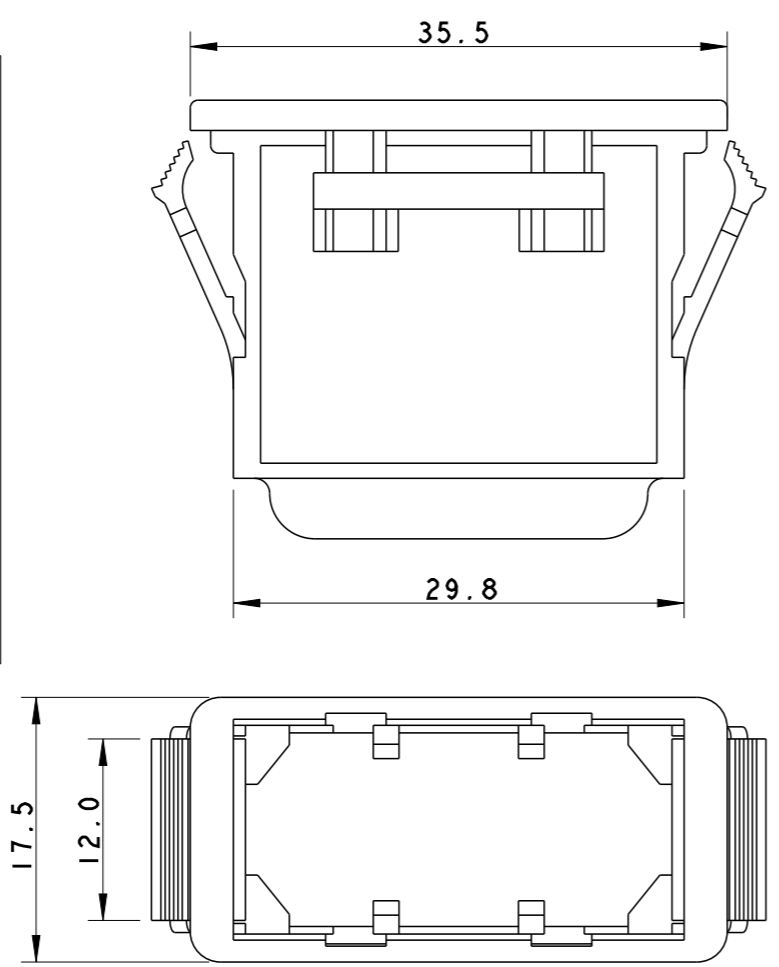
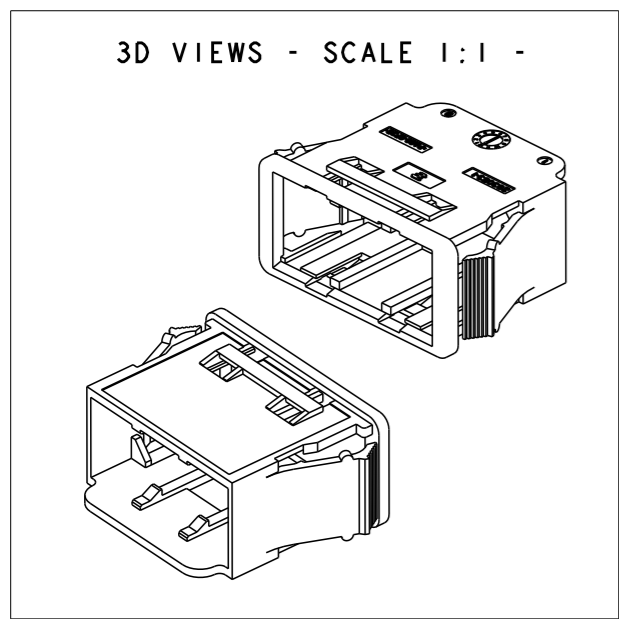

293053-2	WHITE	B
293053-1	BLACK	B
TYCO P/N	COLOUR	REV.

NOTES:

- 1) TE P/N
- 2) RAW MAT'L CODE
- 3) DATE CODE
- 4) MOULD CAVITY IDENTIFICATION
- 5) TE TRADEMARK
- 6) PACKAGING ACCORDING TO TYCO SPEC 107-20252

- 7) TO BE USED ON PANEL MOUNT VERS.
- SPRING CLAMP VERSION PLUG AND RECEPTACLE (SEE TE C-DWGS 293046, 293045)
  - SCREW VERSION PLUG AND RECEPTACLE (SEE TE C-DWGS 293049, 293047)
  - CRIMP VERSION PLUG AND RECEPTACLE (SEE TE C-DWGS 293052, 293051)

THIS DRAWING IS A CONTROLLED DOCUMENT FOR TYCO ELECTRONICS CORPORATION IT IS SUBJECT TO CHANGE AND THE CONTROLLING ENGINEERING ORGANIZATION SHOULD BE CONTACTED FOR THE LATEST REVISION.

DIMENSIONS:	TOLERANCES UNLESS OTHERWISE SPECIFIED:
mm	0 PLC ±0.3
	1 PLC ±0.3
	2 PLC ±0.3
	3 PLC ±0.3
	4 PLC ±0.3
	ANGLES ±1
MATERIAL	FINISH
PA66 GF25 UL94 V0	-

DWN	U. AIME	05MAY2006
CHK	U. AIME	05MAY2006
APVD	G. TURCO	05MAY2006
PRODUCT SPEC	108-20268	
APPLICATION SPEC	-	
WEIGHT	-	
CUSTOMER DRAWING		

**Tyco Electronics** AMP Italia S.p.A.  
 C.so F.lli Cervi 15 Collegno (TO)

NAME: **TYCO NECTOR\* PANEL MOUNT FRAME FOR 3 POS. CONN.S**

SIZE	CAGE CODE	DRAWING NO	RESTRICTED TO
A3	00779	C-293053	-

SCALE: 2:1 SHEET 1 OF 1 REV B